

New thinks new *advantages...*

Yeni fikirler, yeni *fırsatlar...*



NOBILIS DC M1
Seating System Solution

Generated by The 2021 Product Strategy Of Teknotrim Co. Vision



The presentation has been prepared by Teknotrim Sales & Marketing Department

Company Location



- ✓ As Teknotrim , we produce seating system in 6.000m² closed production area
- ✓ We have welding , foaming , molding , stamping , profile bending , cutting , sewing , final assembly workshops with incoming and outgoing storages.
- ✓ With all necessary production lines and machineries, we are completely integrated Corporation.



Welding & Foaming Process



We have 10 manual welding cells and robotic welding operations



We can make our own foam design and production capability. We produce more than 420.000 units backrest and seat cushion foam per year.



TEKNOROB is our group company and all automation and linear robotic system needs are satisfied , developed and integrated by our group.



With highest and flexible robotic system usage advantage , all welding operations are made by robotic welding machines and all necessary welding apparatus and fixations are designed appropriate for robotic welding process



www.teknorob.com

Foam Density Control Process

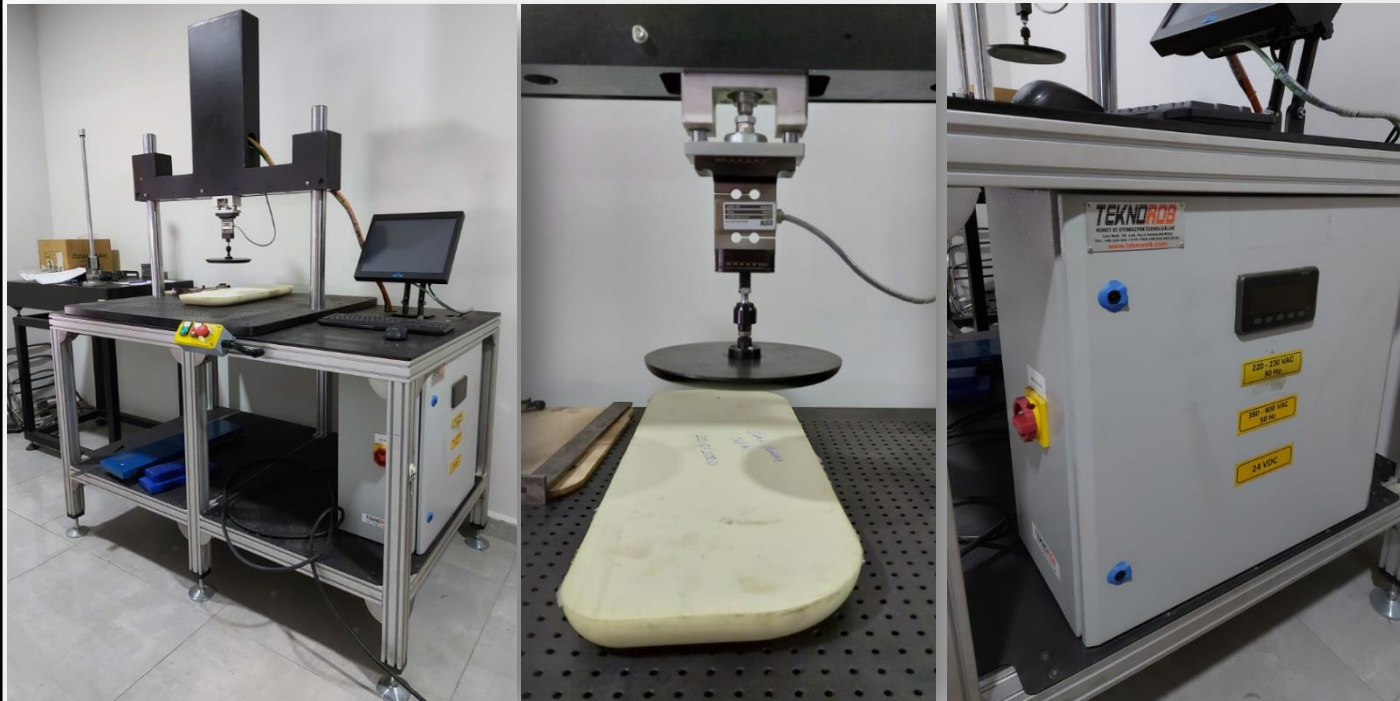

The foam density control machine has been designed and produced by our group company of TEKNOROB for our laboratory.

Hereby holding this machinery , we can make density control in prototype , pre-serial and serial phase of the product in various periods and all datas have been reported and followed up by our Quality Department regularly.

The foam density control machine is controlled , tested and funded due to it is considered as a national technology by The Scientific And Technological Research Council Of Turkey. The machinery is also patented by TEKNOROB.

www.teknorob.com



TUBITAK

THE SCIENTIFIC AND TECHNOLOGICAL RESEARCH COUNCIL OF TURKEY

«...research is to see what everybody else has seen , and to think what nobody else has thought...»

Albert Sizent

Research & Development Capability

Research & Development consists of two main departments as Industrial & Mechanical Design Center and Product Development & Application Center

Our technical capability can be considered with following topics;

1. Industrial Product Design
2. Mechanical Design
3. Product Development & Applications
4. Software & electrical design and application supported by Teknorob R&D
5. Test & Documentation Process
6. Project Management

Data Base Management

We use Catia V5 and Autocad program and also ERP data base system program called MICROFLY PROFESSIONAL which has been developed mad most of the interface software codes by our R&D Software Specialists

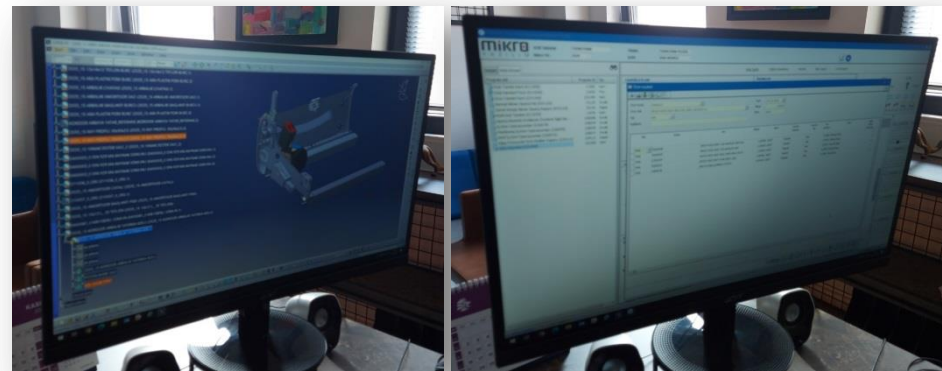

Sewing & Last Montage & Storages



Packing & Storage Process

Management

Mustafa Samancı
General Manager

Bilgehan Gültekin
Sales & Marketing Manager

Fatih Vural
Foreign Trade Manager

Şenol Aladağ
R & D / Strategic Purchasing Manager

Sevilay Samancı
Account Manager

Sevilcan Ceylan
Quality Manager

Taner Peker
Logistic & Production Manager

Cüneyt Çetin
Project Executive

Abdullah Ayduğan
Quality Chief

Mustafa Tokmak
Metal Production Line Chief

Özgür Ece
Foaming Production Line Chief

Kazım Temel
Upholstery & Last Montage

- Totally we have 28 white collar and 95 blue collar staff
- Total worker is 123



Commercial Vehicle
Seating Systems



NOBILIS DC

(M1)

Ambulance



NOBILIS DC M1 Seating System Solutions

- The new generation ambulance M1 seating system solution of NOBILIS DC M1 has been constructed and designed for our respectable clients globally
- Hereby designing and producing of the NOBILIS DC M1 seating system solution , as TEKNOTRIM , we notably aim to show off that we can make customize solutions as well.

NOBILIS DC M1
New Generation Ambulance Seating System



NOBILIS DC

(M1)

Ambulance



Nobilis DC M1

Important Notes & Project Plan

NOBILIS DC M1 new generation ambulance seat has been designed and constructed for our potential and existing respectable clients operate in all over the world. Therefore, connection details , installation type of the seat ,optional variations can be adapted to NOBILIS DC M1 by our client's expectations.

NOBILIS New generation ambulance seating system is not including only doctor seat with full of functions as Nobilis DC M1 but also including assistant seat called Nobilis M3 based on the same visual details but fixed back with upward foldable seat cushion.

Due to main structure of Nobilis DC M1 is as the same as with Apeiron DC M1 , it has already been tested based on FORD vehicle chassis and waiting for the extension also for Mercedes Sprinter.

Industrial and mechanical design process of the Nobilis DC M1 is completed and it is passed over a molding process for backrest foam , completely back and lower seat cushion vacuum plastic covers. It would take about 6 weeks.

SOP (Start Of Production) date of Nobilis DC M1 is **1st Q of 2021**



NOBILIS DC

(M1)

Ambulance

«...maybe I can say for Nobilis DC that this is what we can do for the time being and hope it is the best one till when to do much more better one...»

Mr. Senol Aladag (R&D Manager / Teknotrim)

Industrial Design Capability



NOBILIS DC
Seating System Solutions

- Industrial design is made and managed by our R&D department by getting all essential technical and design expectations and priorities from our respectable clients by making several technical meetings
- Notably to get also claims , feedbacks or decades made by any of the independent assessments concerning to healthy care are our focal point of the way to make an industrial designing activities
- Priorities that are already specified by our clients are also our main priorities while making an industrial design



NOBILIS DC

(M1)

Ambulance



24,50 Kg

Based on standard specified features

Nobilis DC M1

Standart Features

Constructed based on metal structure fulfilling M1 / ECE 95 - 28 ; ECE R14 and EN 1789 International EU regulations

450mm backrest and seat cushion width and 450 mm seat cushion depth

Fixed backrest integrating to the main backrest structure directly without any additional welding operation.

3P Safety belt mechanism running into the backrest by satisfying of «ALL AGE» using expectations.

170° Back reclining system by special gearwheel system which is completely developed by Teknotrim R & D Department specially.

360° Rotate system by stopped in each 90° movement. The rotate system is designed and constructed based on special bearing system in order to make a movement effortlessly

Upward folding seat cushion mechanism by hidden piston

Maximum sterilization by covering all mechanical and visual areas with vacuum plastic parts.

Base connection can be applied to each different connection points

Trimmed by artificial leather fulfilling ECE R 118 Flammability Standards



NOBILIS DC

(M1)

Ambulance



Nobilis DC M1

Optional Features

Availability of applying 4P automatic safety belt running into the backrest

Special safety belt warning system applied into the seat cushion

Upward foldable armrest can be applied on both sides of the backrest

Special embroidery or hem application on the upholstery

Different color variations can be trimmed to the seat

Special leg fixation alternatives

Use Ral 9022 light grey vacuum plastic color instead of Ral 9005 black



NOBILIS DC

(M1)

Ambulance

«...hereby generating of the Apeiron DC M1, totally we succeeded to build completely new seating system solution base by getting maximum standardization and lean methodology in production side...»

Mr. Mustafa Samancı (CEO / Teknotrim)

Differences Between Apeiron DC and Nobilis DC

Plastic Back Cover Shape



Backrest Foam Shape



Lower Seat Cushion Cover Shape



Similarity Between Apeiron DC and Nobilis DC

Except specified differences above , main structure of the seat , functionalities and critical parts with accessories and options are the same.



NOBILIS DC

(M1)

Ambulance

3P Automatic Safety Belt Running Into The Backrest

3P Automatic safety belt direction can be placed on both sides of the headrest. Therefore , the safety belt retractor can be placed by the position of the seat in a vehicle.

Due to retractor of the seat belt is placed inserted of the headrest and special side plastic direction , a possibility of friction or deflection of the belt or deformation on the upholstery is getting minimized.

With ALL AGE main feature , it is aimed to avoid that might be occurring of injures , wound or any of skin disease



In order to avoid any finger pressure , injures and also hurt notably on hip area of the body due to top edge of the safety belt buckle exceeds to seat cushion surface , the seat buckle is inserted to the side plastic cover and fixed of locking angle by ECE 95/28 international EU regulation norms.



NOBILIS DC

(M1)

Ambulance

Availability Of Using 4P Automatic Safety Belt

Apeiron DC M1 main seat structure has been designed to make it appropriate to use of 4P automatic safety belt instead of 3P automatic safety belt when it is requested by customers.

Due to Apeiron DC M1 main structure is designed as a compact design, retractors can be inserted to the headrest

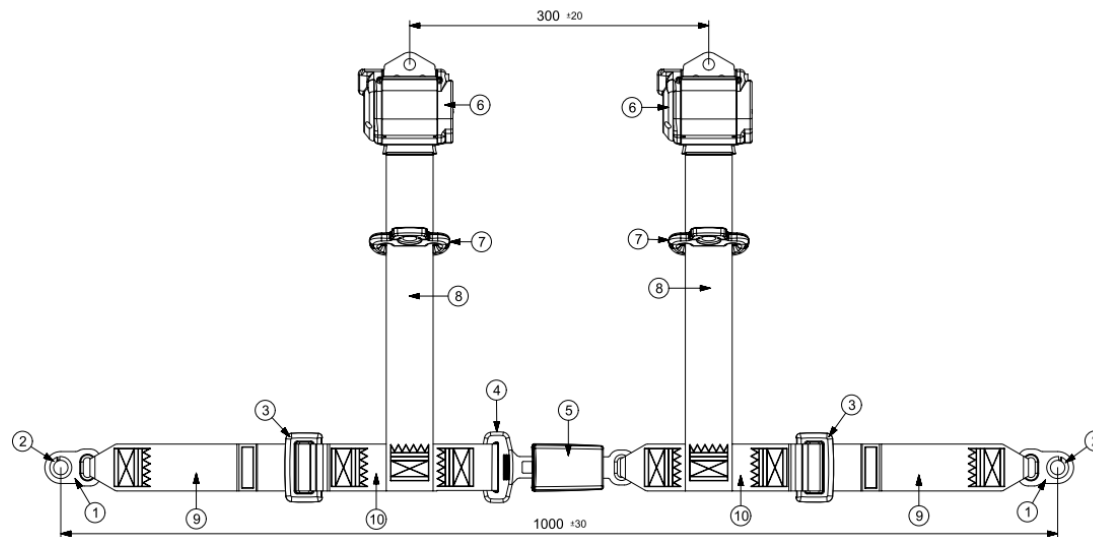

NOBILIS DC

(M1)

Ambulance

Maintenance Of Safety Belt Mechanism



In order to achieve of the retractor due to any of defection or claim , it is enough to dismantle of the bolts located in six different points that are specified and showed off the illustration.

Only one worker can rip the bolts out and achieve to the retractor for repairing or changing. After repairing or changing operation , it is truly easy to put the back plastic cover on the backside of the backrest by screwing of the bolts for fixation.



APEIRON DC

(M1)

Ambulance

170° Back Reclining Mechanism

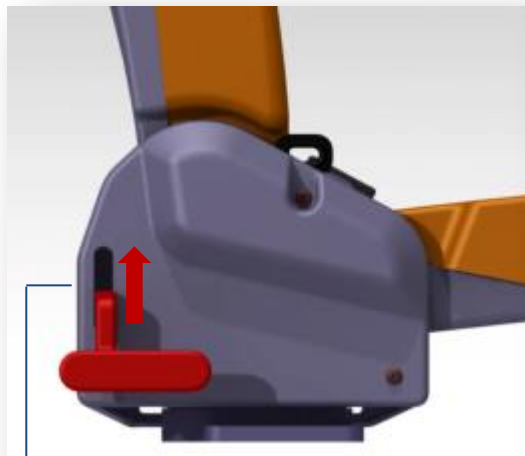

1st Step

In a seating position, back reclining function is being released when the back reclining arm pulled up slightly. After pulling up to reclining arm ,gearwheel that is located into the base frame is released from locking system.

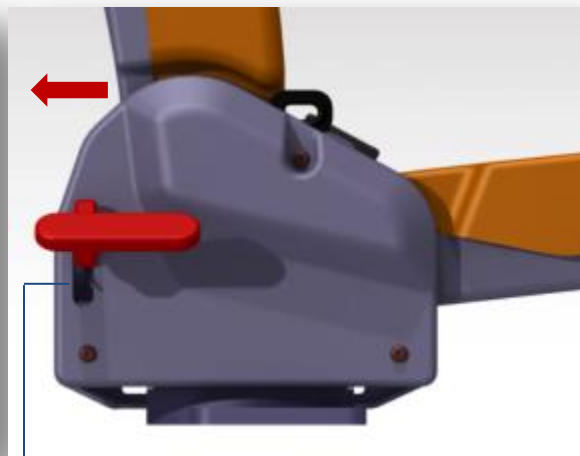

2nd Step

After activation of 1st step , it is enough to recline of the backrest with your body smoothly.

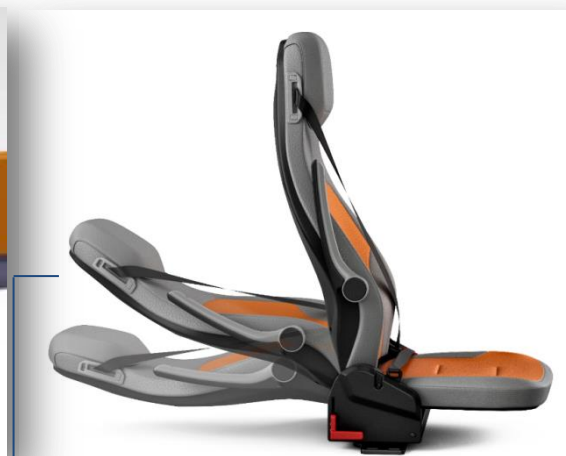

3rd Step

There is a locking system activating when the back reclining system is coming to 170° and it is fixed.



NOBILIS DC

(M1)

Ambulance

360° Rotate Mechanism



1st Step

In a seating position , there is a the plastic arm colored red on left side of the seat base. It is enough to move of the arm to the backward , the special metal stick is pulled back which is triggered by a special spring from the adaptor and rotate system is released.

2nd Step

After activation of 1st step , rotate mechanism is locked in each stopping point of 90° . Therefore the rotate system is completing his rotation after 4 locking points completely.



NOBILIS DC

(M1)

Ambulance

Upward Foldable Seat Cushion



Upward Foldable Armrest



NOBILIS DC

(M1)

Ambulance

Sterilization & Security



In order to highest sterilization and security expectation and priorities , all mechanical and critical visual areas that relating to humanity health and life safety are isolated by covering vacuum plastic parts completely.

NOBILIS DC

(M1)

Ambulance

Trimming Variations



The trimming operation will be made as **seamless** by vacuum upholstery technology



NOBILIS DC

(M1)

Ambulance

NOBILIS DC M1 AMB. Seat has been tested by ECE 95 / 28 – M1 and EN 1789 / R14 Pull Test based on Ford Vehicle Chassis

Note : Due to the main structure of the seat is the same for Nobilis DC and Apeiron DC , hereby making the R14 ; R16 and R17 tests for Apeiron DC, the test results are also being valid also for Nobilis DC

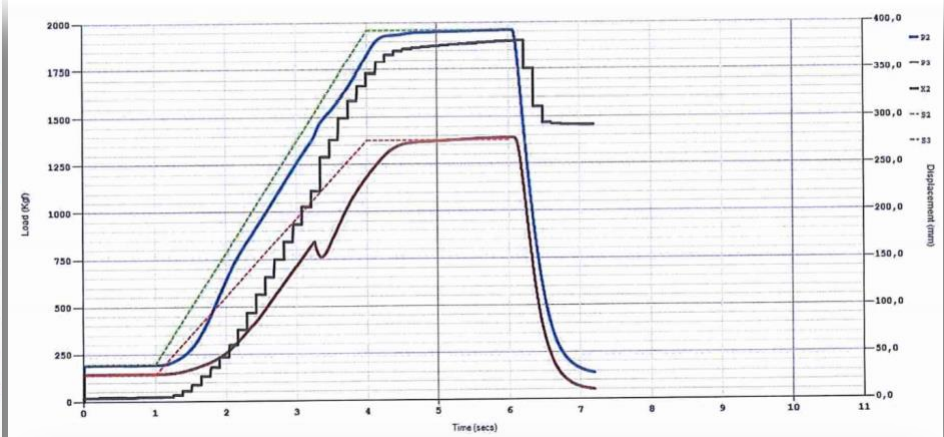

Marca / Mark: EMS Tipo / Type: EMS-TF (Type – 1)	Carga Mínima Minimum Load (daN)	Carga Alcanzada Reached Load (daN)
Entre anclajes superiores <i>Between upper anchorages</i>	1350,0 ± 20	1357,2
Entre anclajes inferiores <i>Between lower anchorages</i>	1918,8 ± 20	1913,3



NOBILIS DC

(M1)

Ambulance

Nobilis DC M1 AMB. Seat has been tested by ECE 95 / 28 – M1 and EN 1789 / R-16 and R17 Energy Absortion Annex-5 and Annex-6

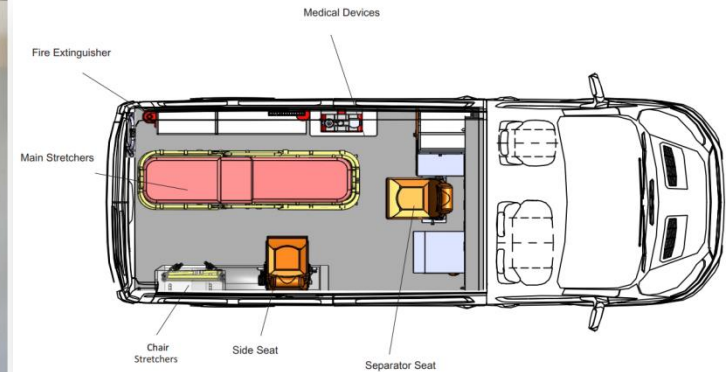
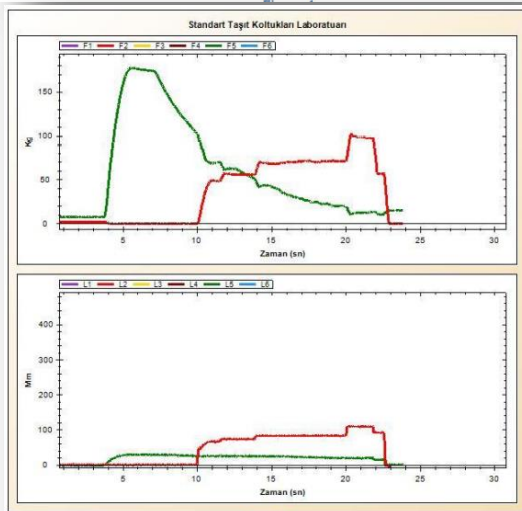

Apeiron DC M1 ambulance seat has been tested based on R16 and R17 regulation norms behalf of EMS under the inspected and reported by IDIADA in Turkey. Hereby completing of all essential tests by EU regulations , Apeiron DC M1 ambulance seat is being accredited product globally.



New thinks new *advantages...*

Yeni fikirler, yeni *fırsatlar...*

Thank You !



The presentation has been prepared by Teknotrim Sales & Marketing Department