

New thinks new *advantages...*

Yeni fikirler, yeni *fırsatlar...*



Enjoy Kids (M3)

Schoolbus Seat



Prepared by Teknotrim Sales & Marketing Department and date is 01.01.2021

Company Location



- ✓ As Teknotrim , we produce seating system in 6.000m² closed production area
- ✓ We have welding , foaming , molding , stamping , profile bending , cutting , sewing , final assembly workshops with incoming and outgoing storages.
- ✓ With all necessary production lines and machineries, we are completely integrated Corporation.



THE HISTORY OF TEKNOTRIM

2015

Teknotrim started to make his own cinema , conference and theatre seating system solution for respectable clients.

2019

Teknotrim decided to access of the commercial vehicle industry by generating the new generation passenger , co -driver, ambulance and special seating system solutions with contemporary design, building upon to start of R&D studies.

Furthermore , Teknotrim obtained ISO TS 9001 ; 14001 and OHSAS 18001 certifications.

2013

Teknotrim Co. has been established to produce main integral metal parts , PU parts and seat foam as semi finished materials for seat manufacturers globally.

2016

In order to hold an integrated facility completely, profile bending technology, stamping , welding technology and robotic systems have been adapted.

2020

Orbis 100 Intercity passenger seat , Apeiron DC and Nobilis DC ambulance seats are designed in scope of the creting the new generation seating system solutions

Teknotrim scheduled to obtaing of ISO TS 16949 quality certification

ERP software of is integrated to all departments to follow all process up through the system in order to hold a full of control on the tracebility , production planning , ordering , R&D activities , quality management , finance and logistic activities.

Welding & Foaming Process



We have 10 manual welding cells and robotic welding operations



We can make our own foam design and production capability. We produce more than 420.000 units backrest and seat cushion foam per year.



TEKNO ROB is our group company and all automation and linear robotic system needs are satisfied , developed and integrated by our group.



With highest and flexible robotic system usage advantage , all welding operations are made by robotic welding machines and all necessary welding apparatus and fixations are designed appropriate for robotic welding process



Foam Density Control Process

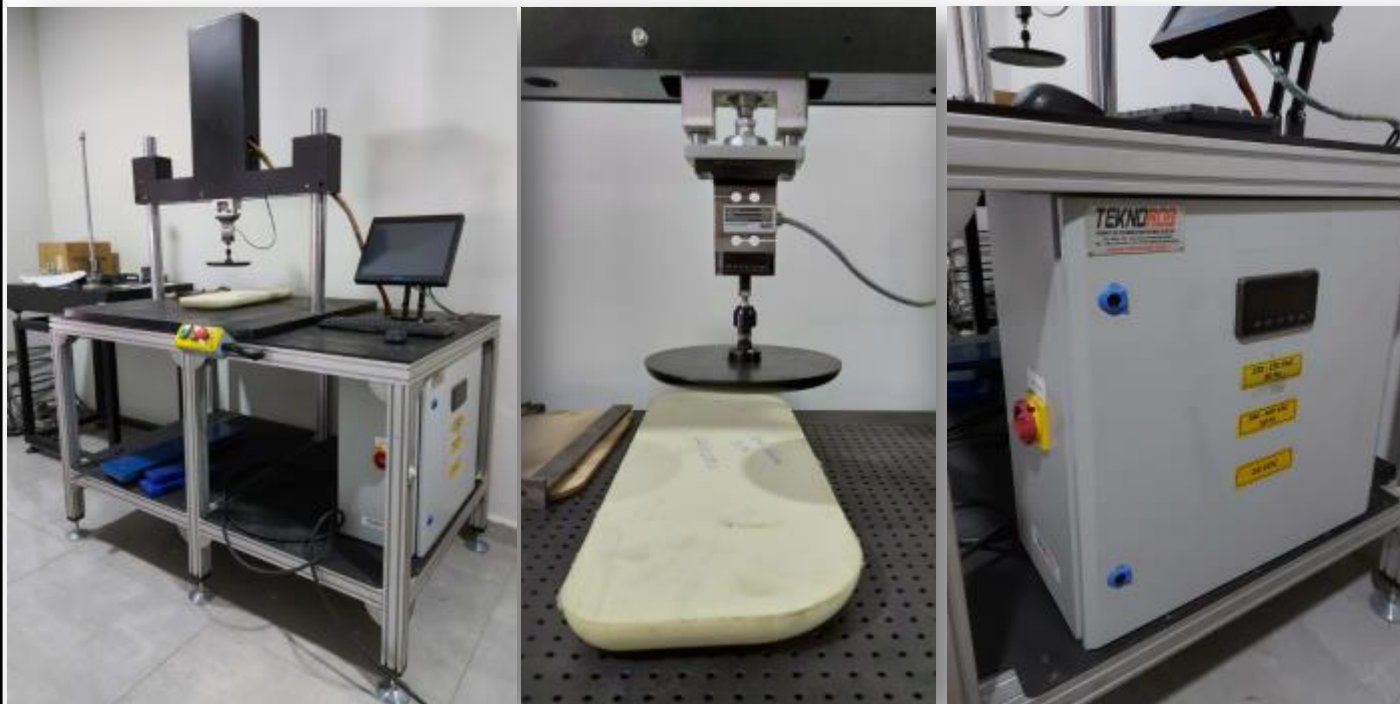

The foam density control machine has been designed and produced by our group company of TEKNOROB for our laboratory.

Hereby holding this machinery , we can make density control in prototype , pre-serial and serial phase of the product in various periods and all datas have been reported and followed up by our Quality Department regularly.

The foam density control machine is controlled , tested and funded due to it is considered as a national technology by The Scientific And Technological Research Council Of Turkey. The machinery is also patented by TEKNOROB.

www.teknorob.com



«...research is to see what everybody else has seen , and to think what nobody else has thought...»

Albert Sizent

Research & Development Capability

Research & Development consists of two main departments as Industrial & Mechanical Design Center and Product Development & Application Center

Our technical capability can be considered with following topics;

- 1.Industrial Product Design*
- 2.Mechanical Design*
- 3.Product Development & Applications*
- 4.Software & electrical design and application supported by Teknorob R&D*
- 5.Test & Documentation Process*
- 6.Project Management*

Data Base Management

We use Catia V5 and Autocad program and also ERP data base system program called MICROFLY PROFESSIONAL which has been developed mad most of the interface software codes by our R&D Software Specialists

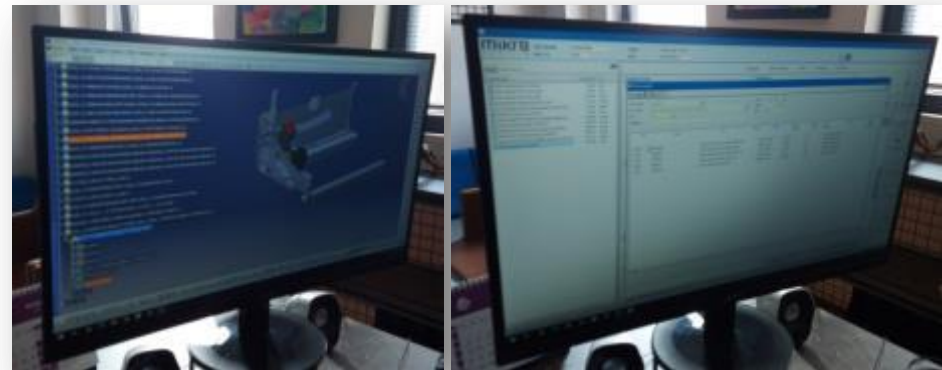

Sewing & Last Montage & Storages



Packing & Storage Process

Management

Mustafa Samancı
General Manager

Bilgehan Gültekin
Sales & Marketing Manager

Fatih Vural
Foreign Trade Manager

Şenol Aladağ
R & D / Strategic Purchasing Manager

Sevilay Samancı
Account Manager

Sevilcan Ceylan
Quality Manager

Taner Peker
Logistic & Production Manager

Cüneyt Çetin
Project Executive

Abdullah Ayduğan
Quality Chief

Mustafa Tokmak
Metal Production Line Chief

Özgür Ece
Foaming Production Line Chief

Kazım Temel
Upholstery & Last Montage

- Totally we have 28 white collar and 95 blue collar staff
- Total worker is 123



Commercial Vehicle
Seating Systems



Enjoy Kids

(M3)

Schoolbus



- Constructed based on M3 main structure
- Contemporary design
- Highest ergonomic
- Special unique main structure
- Minimized welding process
- Security
- Weight advantage
- Modular production technology
- Accessory variations



Enjoy Kids (M3)

Schoolbus

Commercial Vehicle Seating System Enjoy Kids New Generation Schoolbus Passenger Seat

Industrial Design And Modular Technology



Enjoy Kids (M3)
Schoolbus

Commercial Vehicle Seating System Enjoy Kids New Generation Schoolbus Passenger Seat

2D Main Dimensions Of The Seat



There are two seat width alternatives as 320mm and 350mm

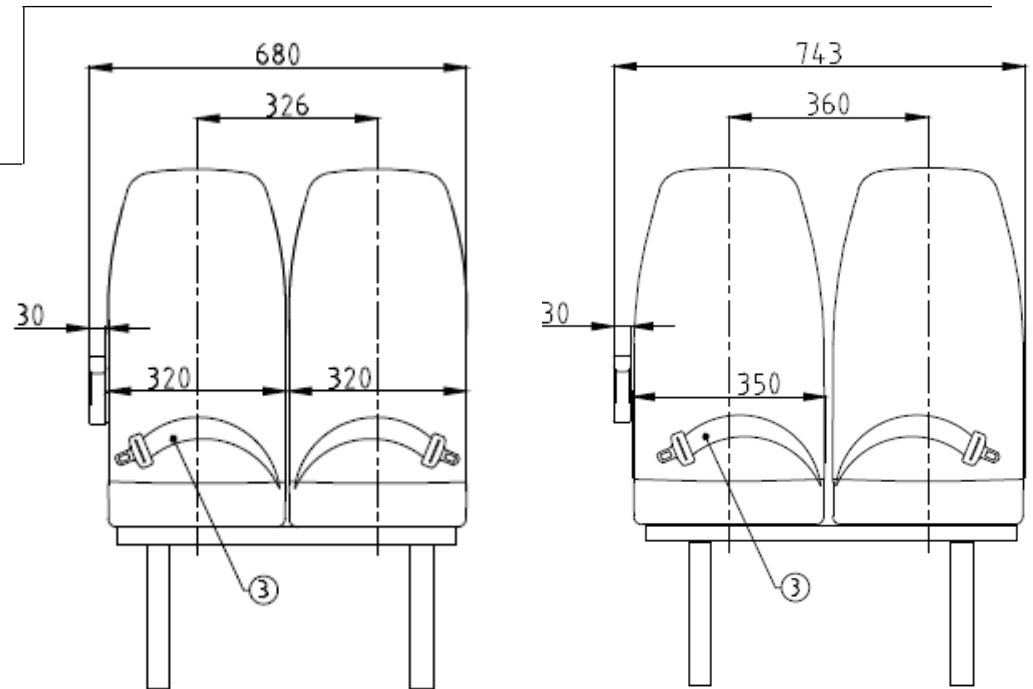

Enjoy Kids

(M3)

Schoolbus



Special Design Upward Foldable Armrest

- Upward foldable armrest has been designed only for Enjoy Kids schoolbus seat model specially by Teknotrim R & D
- Total width of the armrest is 30mm and adaptation of the armrest is made by special mechanism mounted on the backrest of the seat
- Main body of the armrest color is RAL 9002 light grey and upper part of the armrest color is Ral 9005 black



Customer «LOGO» Area

Special Completely Back Plastic Cover

- Completely back plastic cover has been designed only for Enjoy Kids schoolbus seat model specially by Teknotrim R & D
- Back plastic cover available to use 320mm and 350mm backrest foam width
- Back plastic cover consists of %20 fiberglass and special ABS material as RAL 9022 light grey.

Enjoy Kids

(M3)

Schoolbus



Pos	Description	Standart	Optional
1	Fixed Backrest	Standart	-
2	320mm Backrest Foam Width	Standart	
3	350mm Backrest Foam Width	Standart	
4	Back Plastic Cover / Ral 9022	Standart	
5	2P Static Safety Belt / Ral 9005	Standart	
6	2P Automatic Safety Belt / Ral 9005		Optional
7	Upward Foldable Armrest / Ral 9022		Optional
8	2P Hip Restraint		Optional
9	Double Leg Connection	Standart	

Enjoy Kids

(M3)

Schoolbus

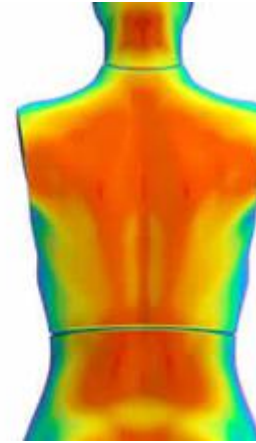
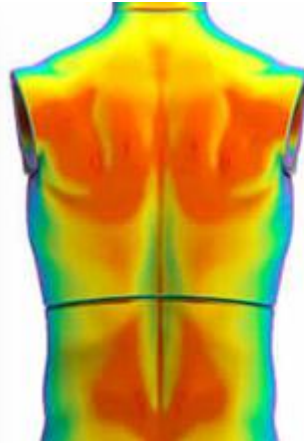

You can see body pressure points colored red in the illustration getting from a ergonomic report . In order to decrease of the body pressure effect , a main shape of the backrest foam of the seat has been designed as thinner and with special «S» form

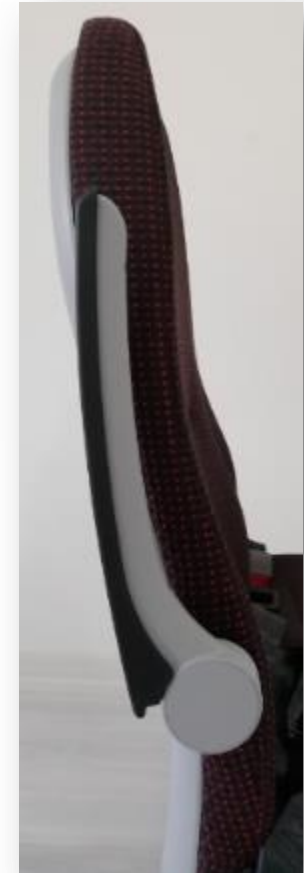
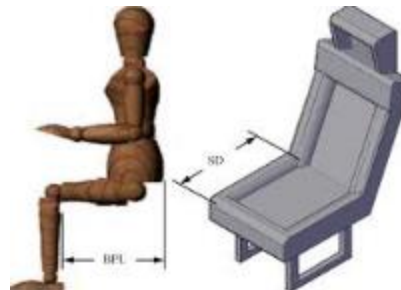

New thinks new *advantages...*

Yeni fikirler, yeni *fırsatlar...*



THANK YOU

Prepared by Teknotrim Sales & Marketing Department and date is 01.01.2021

